

SURFACE TREATMENT		PREVIOUS DRAWING			
GRAINING	UNDER	UNDER	UNDER	UNDER	U1-0E102
✓	✓	✓	✓	✓	
REVISIONS					
NO.	LC NO.	DESCRIPTION	DATE	ZONE	APP. CHECKED DRAWN

鋳物台板用

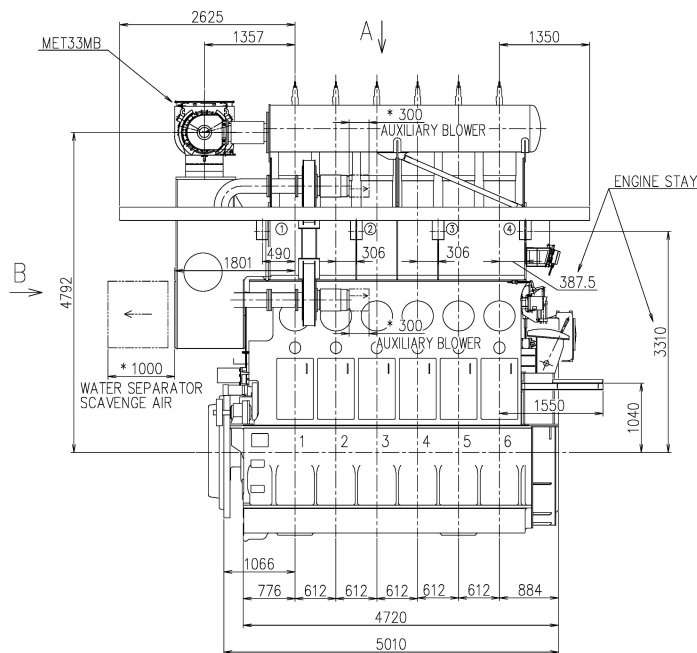

View from exhaust side
排気側より見る

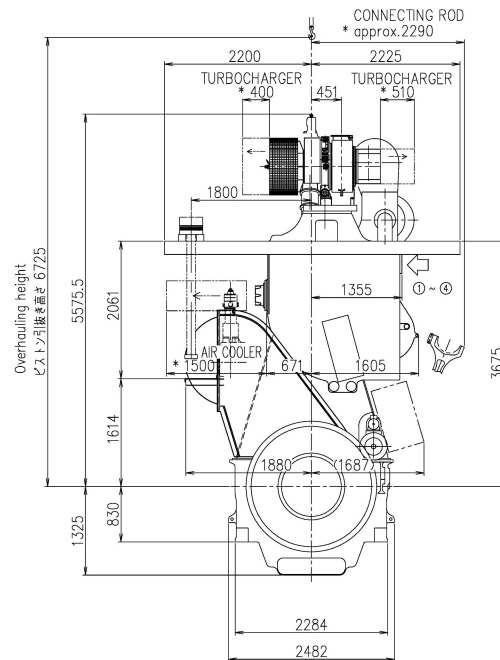

View B
B視

防振ステー配置可能位置

POSITION OF ENGINE STAY

ENGINE STAY TYPE	①	②	③	④	TOTAL	DRAWING NO.
FRICITION CASE1	○	○	○	○	4	U2-1E001
CASE2	○			○	2	

*SPACE FOR REMOVAL
開放スペース

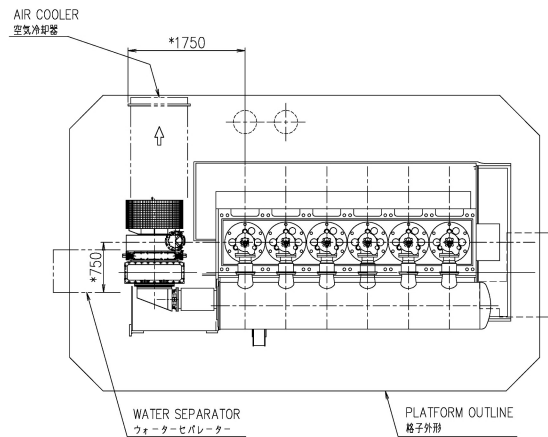

View A
A視

COMMON VARIATION OF TOLERANCE (M/M)	RATINGS OF NOMINAL DIMENSION	OVER	OVER	OVER	OVER	OVER	OVER	OVER	OVER	
		0.5 TO 30	30 TO 120	120 TO 400	400 TO 1000	1000 TO 2000	2000 TO 4000	4000 TO 8000	8000 TO 16000	
TOLERANCE		±0.1	±0.2	±0.3	±0.5	±0.8	±1.2	±2.0	±2.0	±2.5

ACAD

THIS DRAWING IS THE PROPERTY OF JAPAN ENGINE CORPORATION AND SHALL NOT BE REPRODUCED, NOT BE USED TO FURNISH ANY INFORMATION FOR MAKING DRAWINGS OR APPARATUS EXCEPT FOR THE CASE WHERE JAPAN ENGINE CORPORATION AGREES WITH WRITTEN MATERIALS.

1 ENGINE OUTLINE VIEW				1		
1 機関全体外形図				1		
PART NO.	MARK	DESCRIPTION	MATERIALS	QTY PER SET	TOTAL	QUANTITY PER SET
開発部		6UEC33LSE-C2				
江戸		ENGINE OUTLINE VIEW				
木下		(MET33MB)				
CHECKED	吉川	CHECKED			1/1	
DRAWN		DRAWN			00-00	
3rd ANGLE PROJECTION		SCALE	DATE DRAWN	2020-09-08	DRAWING NO.	U1-0E105
We'd shall comply with JIS (Japan Industrial Standards)		Scale		1/40	REVISIONS	
Metric shall comply with JIS unless otherwise specified.					設計	