

PREVIOUS DRAWING		U1-OM032	
REVISONS			
NO.	LC NO.	DESCRIPTION	(DATE)

For Tier2  
For Tier3 (LP-SCR)

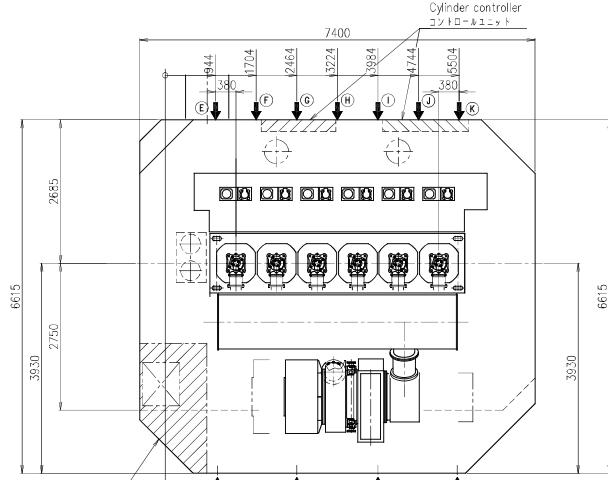

Position of engine stay attachment.  
← : 防振ステー配置位置

Type	Total	Exh. side					Pump side					○: Standard position △: Optional position Optional position can be applied as below. (H) → (G) or (I) (G) → (F) or (H) (I) → (H) or (J)			
		A	B	C	D	E	F	G	H	I	J		K		
CASE1	Friction	3	○	×	○	○	×	×	×	×	×	×	×	×	×
CASE2	Friction	3	○	○	×	○	×	×	×	×	×	×	×	×	×
CASE3	Hydraulic	4	○	×	×	×	×	×	×	×	×	×	×	×	×
CASE4	Friction	4	○	×	×	×	×	×	×	×	×	×	×	×	×
CASE5	Friction	3	×	×	×	×	×	○	△	△	△	○	○	○	○
CASE6	Friction	4	×	×	×	×	×	△	△	△	△	○	△	△	△

PLAN  
平面図

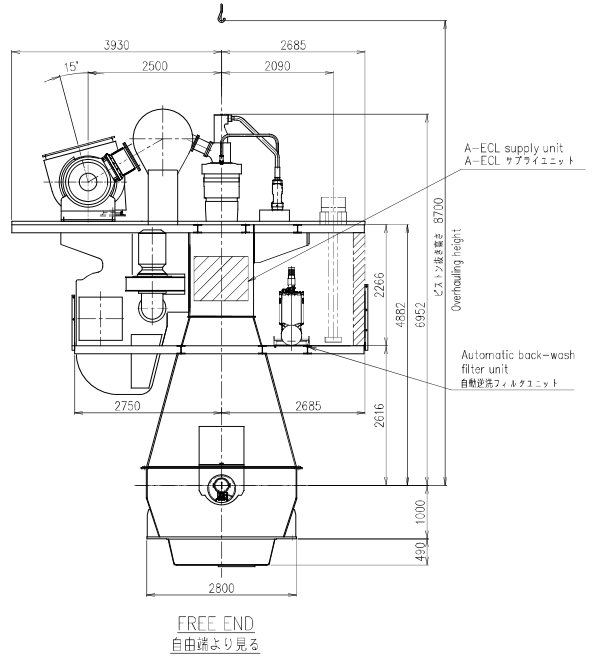
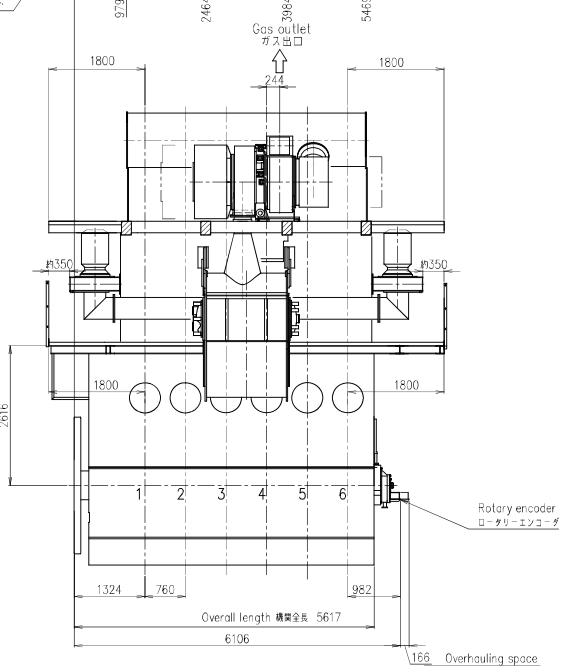
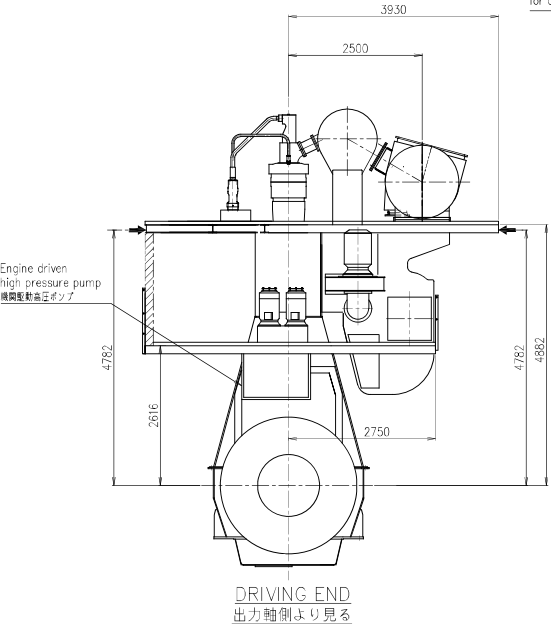

COMMON VARIATION OF TOLERANCE (MAXIMUM)	RATINGS OF NOMINAL DIMENSION	OVER 0.5 TO 4	OVER 5 TO 30	OVER 30 TO 100	OVER 100 TO 400	OVER 400 TO 1000	OVER 1000 TO 2000	OVER 2000 TO 4000	OVER 4000 TO 8000	OVER 8000 TO 16000
TOLERANCE		+ 0.1	+ 0.2	+ 0.3	+ 0.5	+ 0.8	+ 1.2	+ 2.0	+ 2.0	+ 2.5

THIS DRAWING IS THE PROPERTY OF JAPAN ENGINE CORPORATION AND SHALL NOT BE REPRODUCED, NOT BE USED TO PURCHAS ANY INFORMATION FOR MAKING DRAWINGS OR APPARATUS EXCEPT FOR THE CASE WHERE JAPAN ENGINE CORPORATION AGREES WITH WRITTEN MATERIALS.

1 GENERAL ARRANGEMENT (OUTLINE)		全体装置外形図					
PART NO.	WORK	DESCRIPTION	MATERIALS	UNIT PRICE	TOTAL	QUANTITY PER SET	
提出部		APPROVED	6UEC42LSH-Eco				
吉川		GENERAL ARRANGEMENT (OUTLINE)					
木下		全体装置外形図					
CHECKED	吉川	CHECKED	1/1				
DRAWN	吉川	DRAWN	00-00				
1st ANGLE PROJECTION		SCALE	2022.7.26	DRAWING NO.	U1-OM051		REV. NO.
		SCALE	1/50				