

CUSTOMER	
SHIP NO.	
BUILDER	

Engine type	Turbocharger type	Tier2	Tier3	Hydraulic supply oil
				Common system
6UEC50LSJ	MET53MB/-EGBx1	x		x
	MET48MB/-EGBx1	x		x

X : Apply

PROVISIONAL

THIS DRAWING IS THE PROPERTY OF JAPAN ENGINE CORPORATION.
AND SHALL NOT BE REPRODUCED, NOT BE USED TO FURNISH ANY INFORMATION
FOR MAKING DRAWINGS OR APPARATUS EXCEPT FOR THE CASE WHERE
JAPAN ENGINE CORPORATION AGREES WITH WRITTEN MATERIALS.

DESTINATION	SERIAL NO.	MODEL	6UEC50LSJ	
	ORDER NO.	諸管線図集 PIPING DIAGRAM		
	ENGINEERING DEPARTMENT			
	APPROVED _____ K.Edo			
	CHECKED Y.Kinoshita S.Yoshikawa			
	DRAWN _____ K.Amari	DRAWING NO.		REV.
DATE Feb.14th, 2020	SHEETS		C	
Total	SHEETS 26 (with cover)	U7-0K096		

諸管線図名称











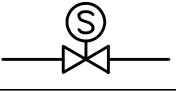

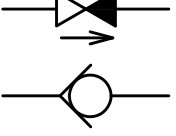
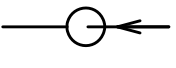
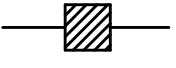
Name of piping diagram

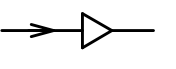

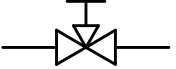
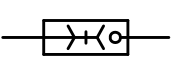
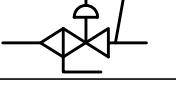
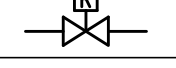
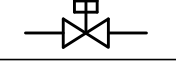





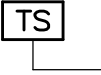

U7-OK096	① 17	Starting air 始動空気管線図
”	② 17	Exh.valve spring air 排気弁エアースプリング管線図
”	③ 17	Fuel oil 燃料油管線図
”	④ 17	Lubricating oil 潤滑油管線図
”	⑤ 17	Axial damper oil 縦振動ダンパー油管線図
”	⑥ 17	Piston cooling oil ピストン冷却油管線図
”	⑦ 17	Hydraulic supply oil (Common system) 油圧作動油管線図 (共油系統)
”	⑧ 17	Actuator oil for exhaust valve 排気弁駆動油管線図
”	⑨ 17	Cylinder lubricating oil for A-ECL system シリンダ注油管線図 (A-ECLシステム)
”	⑩ 17	Turbocharger lubricating oil 過給機潤滑油管線図
”	⑪-1 17	Cylinder cooling water (Uniflow cooling) シリンダ冷却水管線図 (ユニフロー冷却)
”	⑪-2 17	Cylinder cooling water (Loop cooling) シリンダ冷却水管線図 (ループ冷却)
”	⑫ 17	Air cooler cooling water 空気冷却器冷却水管線図
”	⑬ 17	Piston rod stuffing box drain ピストン棒パッキン箱ドレン管線図
”	⑭ 17	Scavenging air trunk drain (For EGR) 掃気トランクドレン管線図
”	⑮ 17	Turbocharger and air cooler washing water and exhaust gas system 過給機空気冷却器洗浄水管及び排気ガス線図
”	⑯ 17	Fire extinguishing 掃気室火災消火装置管線図
”	⑰ 17	Piping diagram for water injection system 注水管線図

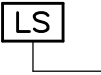
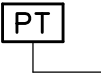
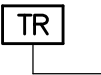
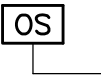
SYMBOLS FOR MAIN ENGINE PIPING DIAGRAM

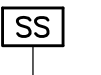
主 機 関 諸 管 線 図 記 号

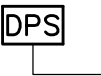
SYMBOLS 記 号	NAME	名 称	REMARKS 備 考
	<u>Nominal inner diameter</u>	<u>称呼口径</u>	
	Crossing pipes, connected	連結管	
	Crossing pipes, not connected	不連結管	
	To bilge	ビルジへ	
	Boss	ボス	
	Boss with plug	プラグ付ボス	
	Joint, bossed	ボス継手	
	Joint, flanged	フランジ継手	
	Blind flange	閉止フランジ	
	Orifice	オリフィス	
	Flexible pipe	フレキシブルパイプ	
	Hopper	ホッパー	
	Hopper with cover	ふた付ホッパー	
	Air vent pipe	空気抜管	
	Siphon	サイフォン	
	Air chamber	エアチャンバー	
	Seal pot	シールポット	
	Stop valve	止め弁	
	Butterfly valve	バタフライ弁	
	Three-way cock	三方コック	(1) T形 (T-PORT) (2) L形 (L-PORT)

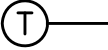
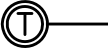
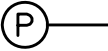
SYMBOLS 記号	NAME	名 称	REMARKS 備考
	Solenoid operated valve	電磁弁	
	Gate valve	仕切弁	
	Safety valve	安全弁	
	Check valve	逆止弁	
	Sight glass	サイトグラス	
	Simplex strainer	単式コシ	
	Duplex strainer	複式コシ	
	Y type strainer	Y形ストレーナ	
	Reducer	レジュース	
	Hose coupling	ホース継手	
	Regulating valve	自動調整弁	
	Self-seal joint	セルフシール継手	
	Filter and regulator	フィルタ及び調圧弁	
	Remote control valve	遠隔制御弁	
	Control valve	制御弁	
	Back pressure valve	背圧弁	
	Regulator	レギュレータ	
	Drain separator (with auto drain)	ドレンセパレータ (オートドレン付き)	
	Electric driven pump	電動ポンプ	
	Air driven pump	エア駆動ポンプ	

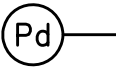
SYMBOLS 記号	NAME	名称	REMARKS 備考
	Pressure switch	圧力スイッチ	
	Temperature switch	温度スイッチ	
	Float switch	フロートスイッチ	
	Limit switch	リミットスイッチ	
	Pressure transmitter	圧力トランスミッター	
	Temperature sensor	温度センサ	
	O ₂ concentration sensor	O ₂ 濃度センサ	
	Mist sensor	ミストセンサ	
	Smoke sensor	スモークセンサ	
	Oil or water level sensor	液面レベルセンサ	
	Differential pressure switch	差圧スイッチ	
	Oil mist detector	オイルミスト警報装置	
Bar type 	Thermometer	温度計	
Dial type 			
Engine side 	Pressure gauge	圧力計	
on Gauge board 			
	U Tube manometer	U字管式圧力計	
	Differential pressure gauge	差圧計	

SYMBOLS 記号	NAME	名称	REMARKS 備考
	Remotely indicated	遠隔指示計	
PI	Pressure indication	圧力指示	
PA	Pressure alarm	圧力警報	
DPA	Differential pressure alarm	差圧警報	
PSD	Pressure slow down	圧力減速	
TI	Temperature indication	温度指示	
TA	Temperature alarm	温度警報	
TE	Temperature emergency stop	温度危急停止	
TSD	Temperature slow down	温度減速	
LI	Level indication	液面指示	
LA	Oil or water level alarm	液面指示	
FI	Flow indication	流れ指示	
FA	Flow alarm	流れ警報	
FSD	Flow slow down	流れ減速	
OI	O ₂ concentration indication	O ₂ 濃度指示	
OA	O ₂ concentration alarm	O ₂ 濃度警報	
MSA	Mist alarm	ミスト警報	
ASD	Auto slow down	自動減速	
pHIA	pH indication, alarm	pH指示、警報	
DIA	Density indication, alarm	比重指示、警報	

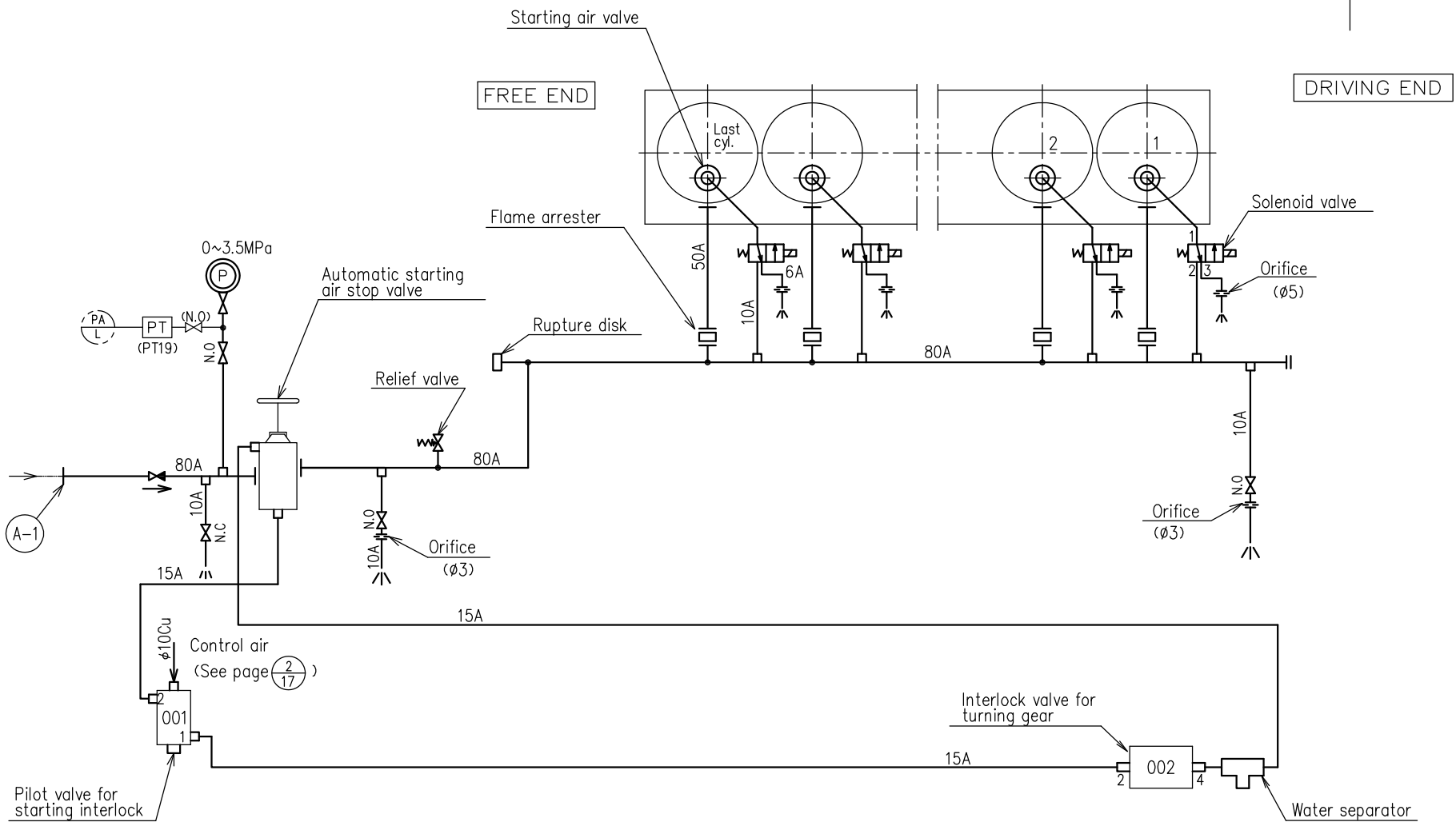

6UEC50LSJ

Piping diagram of starting air
始動空 氣 管 線 図

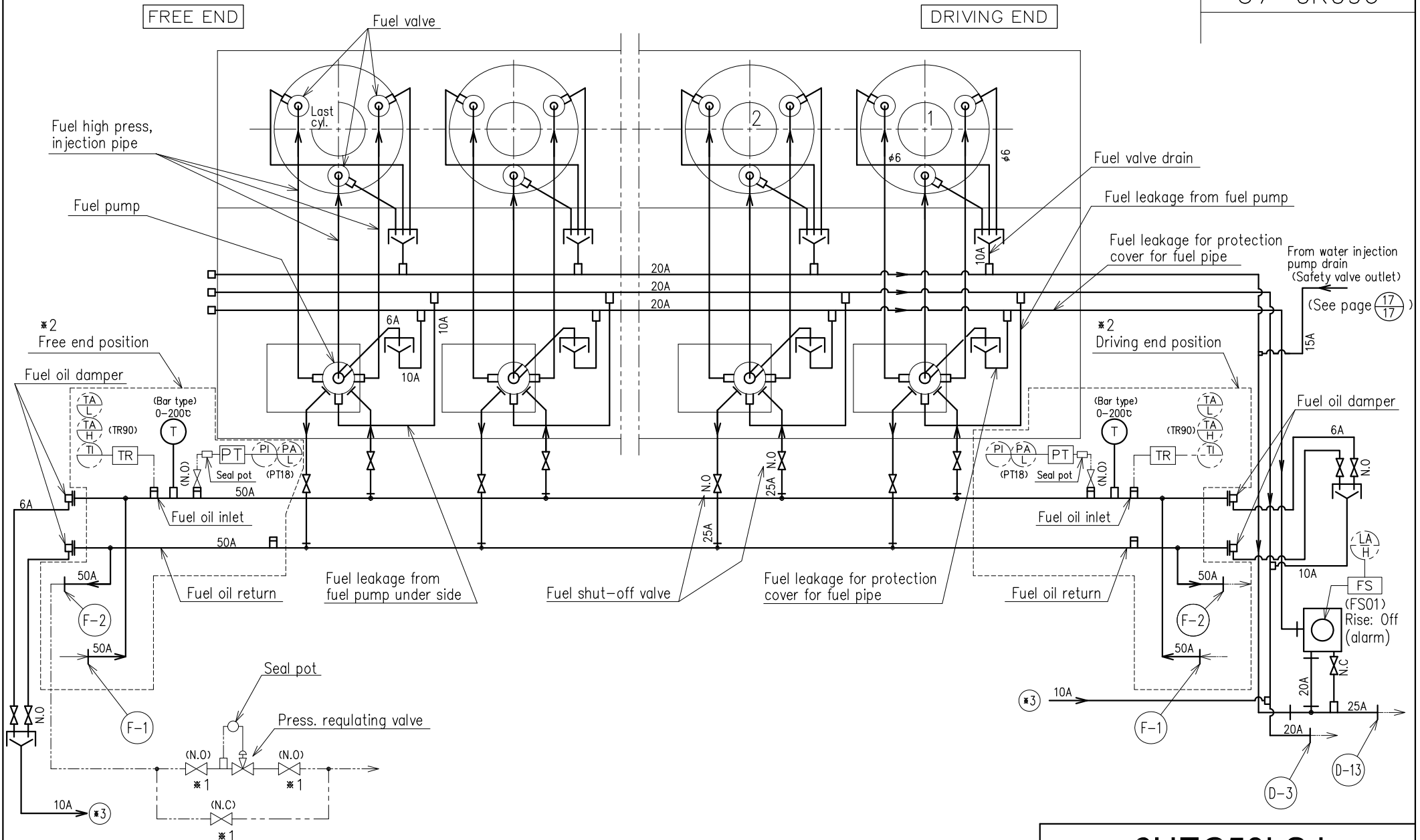

- ※ 1 Supplied by shipyard.
造船所蔵所掌
- ※ 2 That of selecting one of the other.
どちらか一方を選択のこと。

6UEC50LSJ

Piping diagram of
fuel oil

燃料油管線図

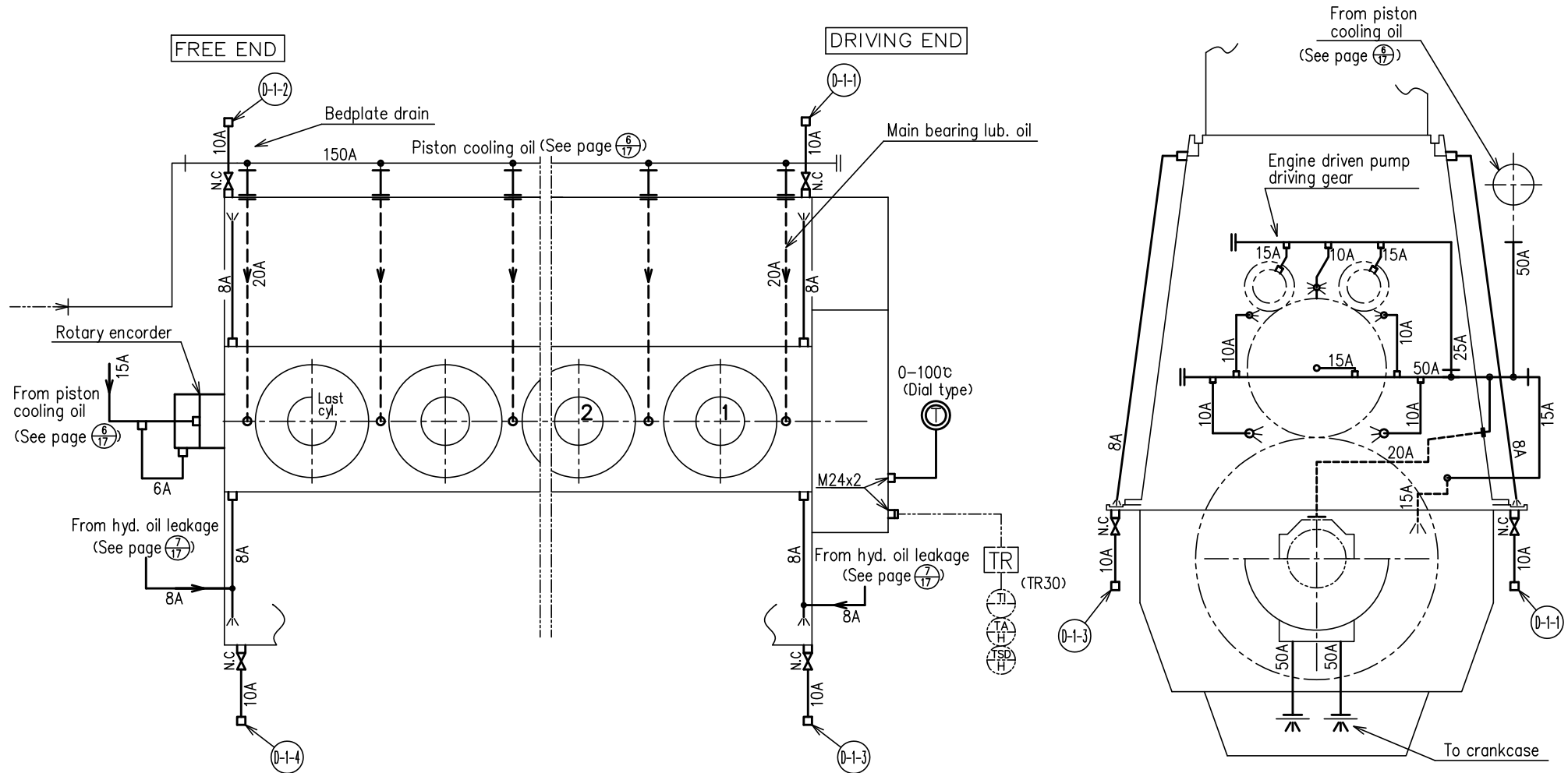

View from driving end

6UEC50LSJ

Piping diagram of lubricating oil
 潤滑油管線図

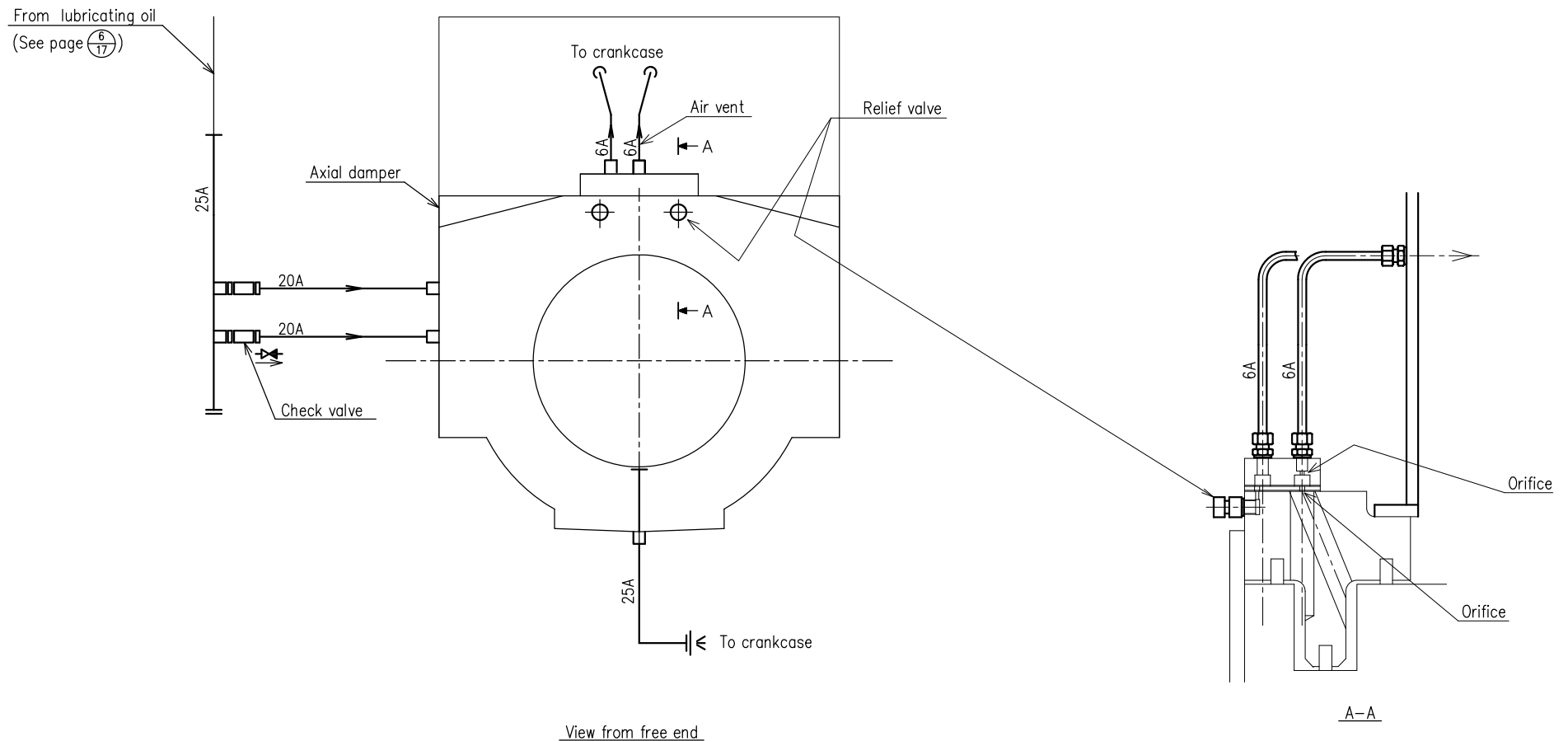

6UEC50LSJ

Piping diagram of
axial damper oil

縦振動ダンパー油管線図

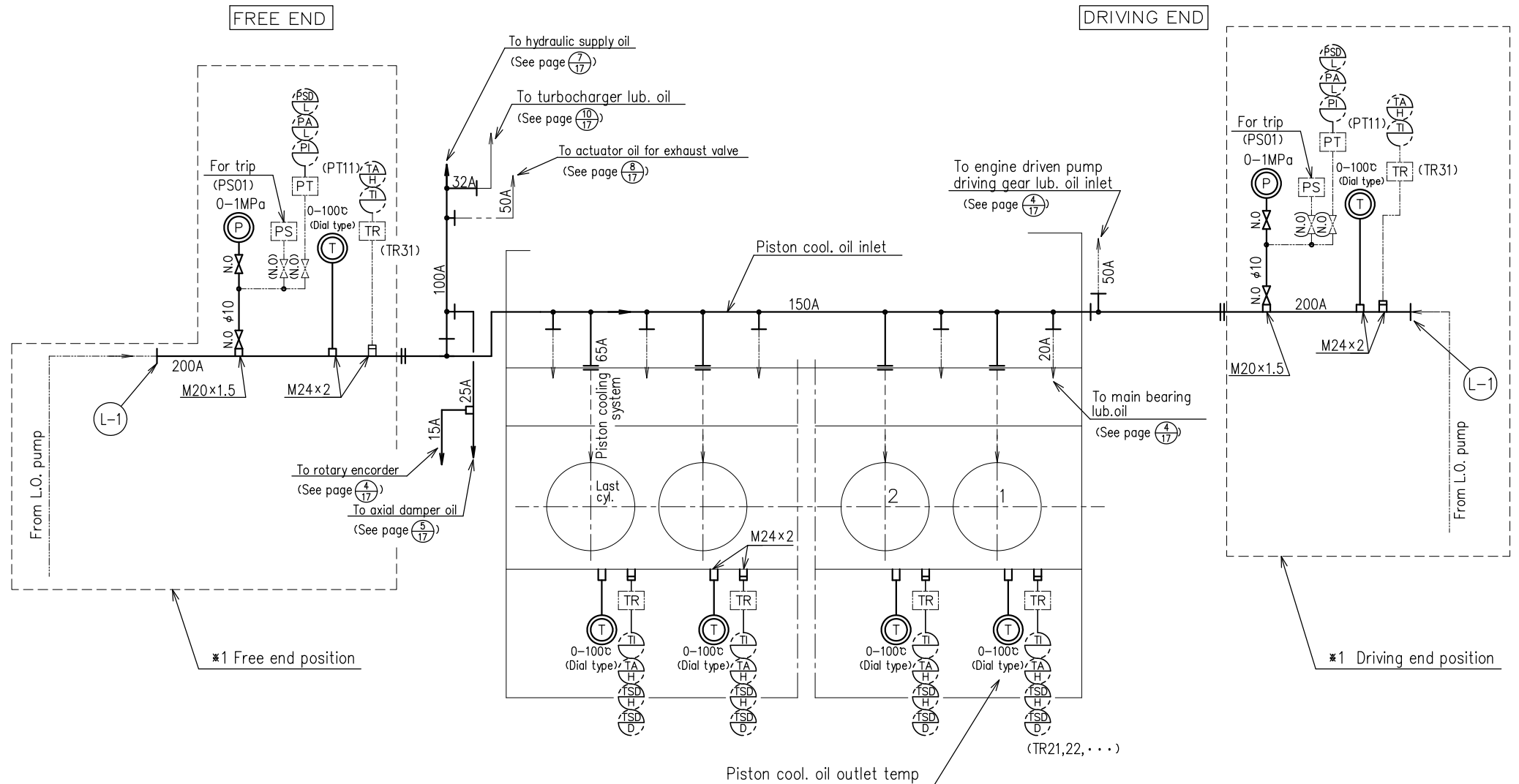

6UEC50LSJ

Piping diagram of piston cooling oil
ピストン冷却油管線図

*1 That of selecting the one of the other.
どちらか一方を選択のこと。

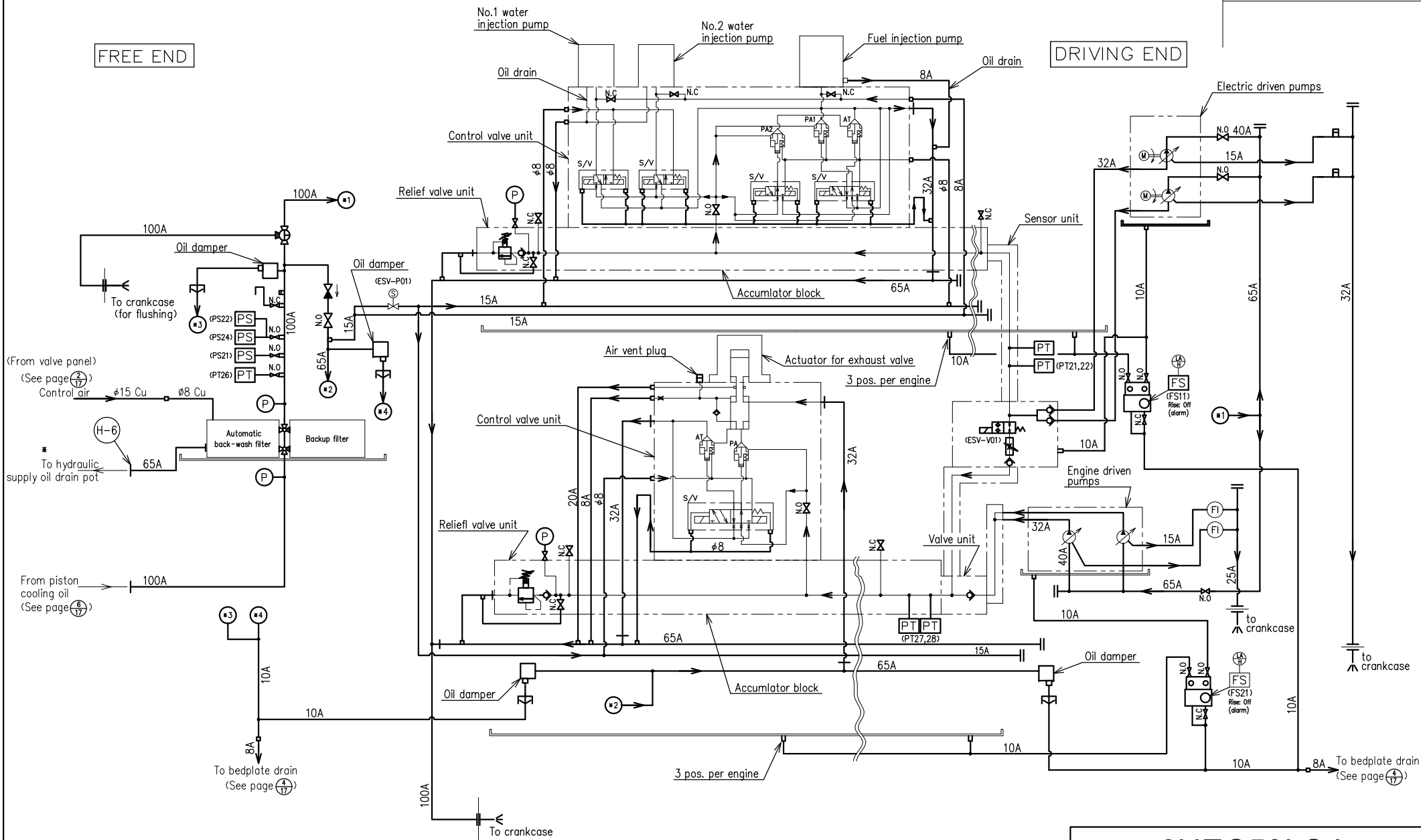

* May not stand up the pipe to prevent the oil reservoir until the drain tank.
 And shall be contact the engine manufacturer if there is a need to stand up the pipe.
 フレンタンクまで油溜まりがでないように管に立ち上げ部を作らないこと。
 配管を立ち上げる必要がある場合はエンジンメーカーに問い合わせること。

6UEC50LSJ

Piping diagram of hydraulic supply oil (Common system)
 油圧作動油管線図 (共油系統)

FREE END

DRIVING END

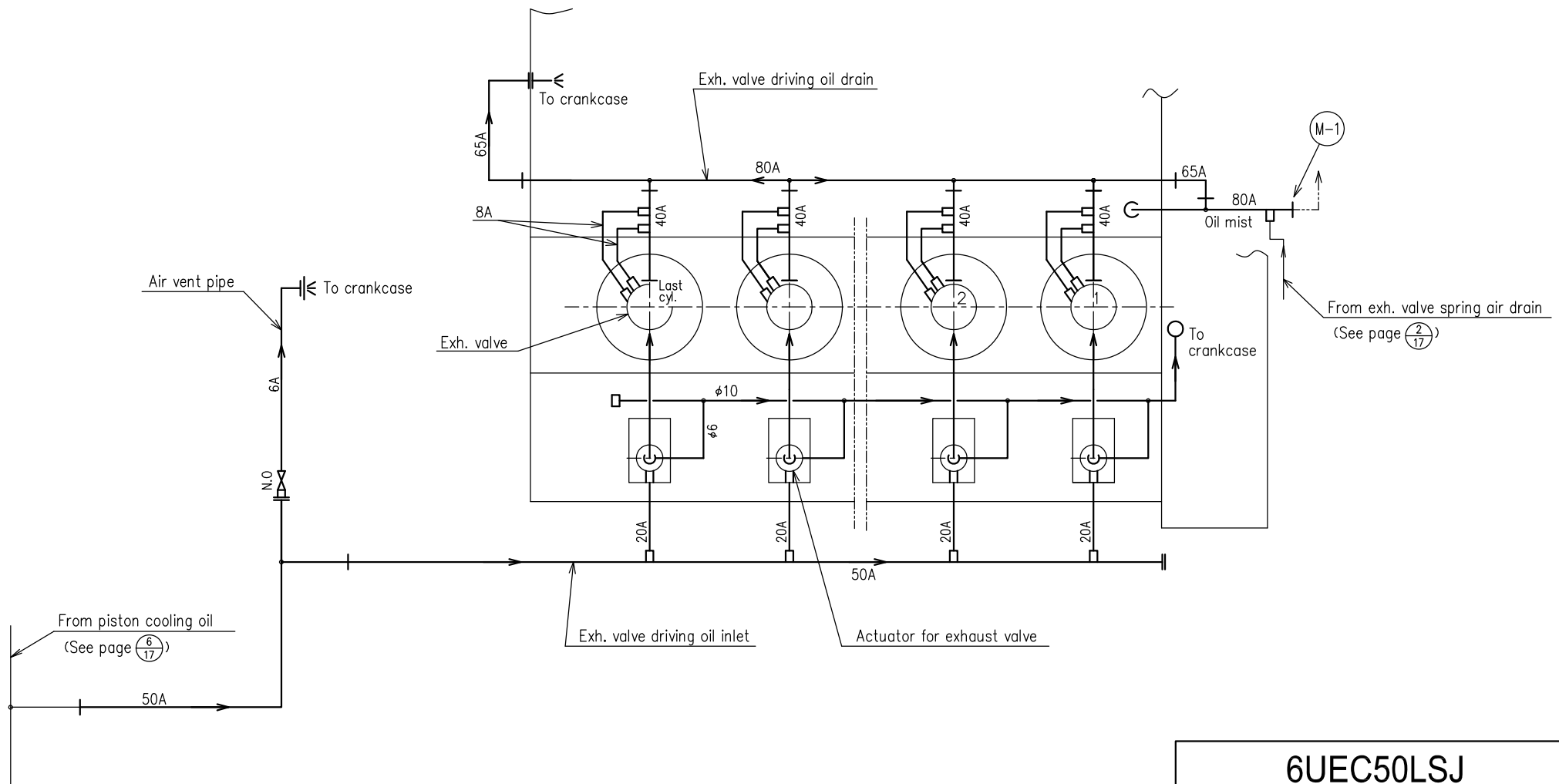

6UEC50LSJ

Piping diagram of
actuator oil for exhaust valve

排气弁駆動油管線図

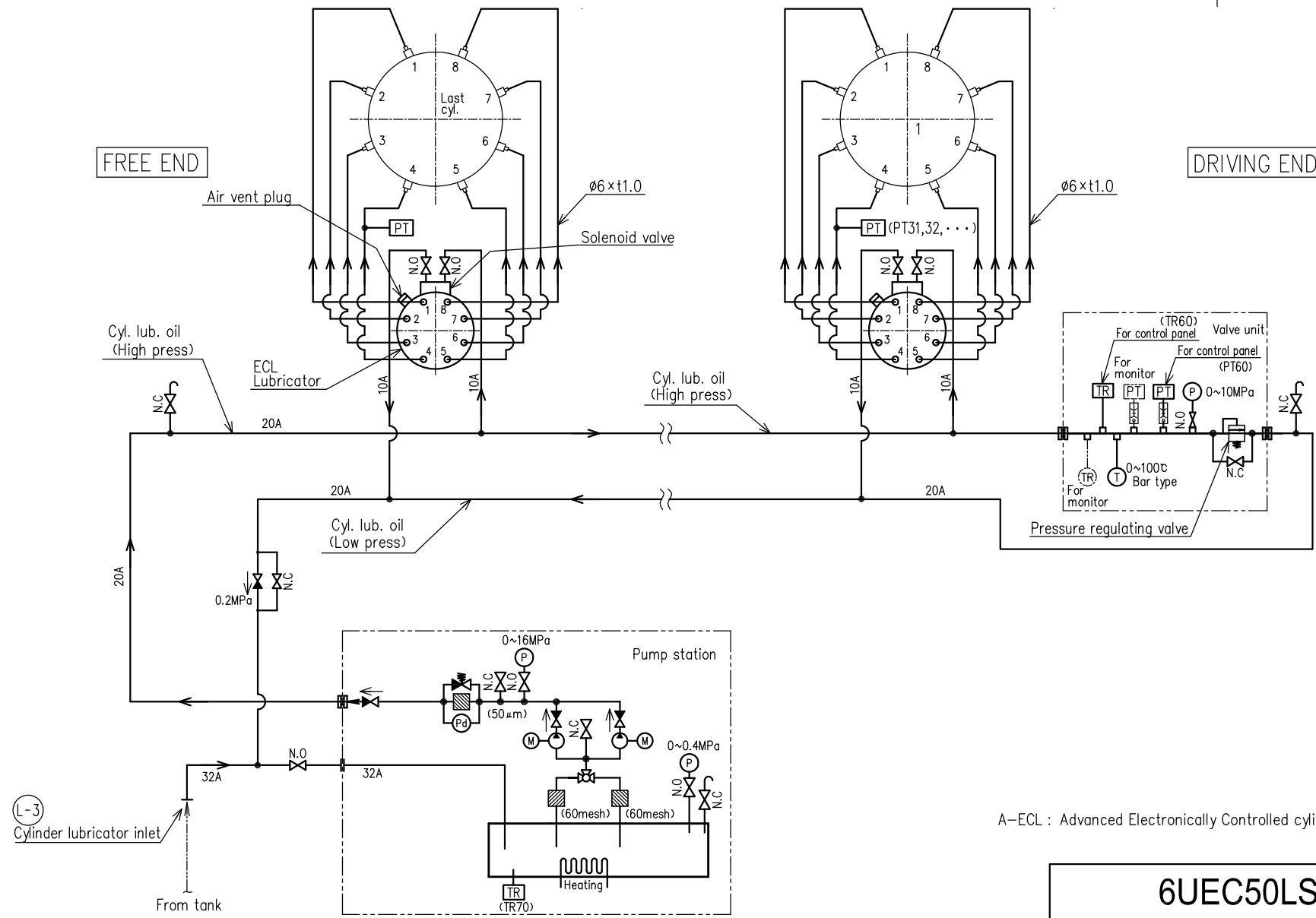

A-ECL : Advanced Electronically Controlled cylinder Lubricating

6UEC50LSJ

Piping diagram of
cylinder lubricating oil for A-ECL system

シリンダ注油管線図 (A-ECL用)

DRIVING END

FREE END

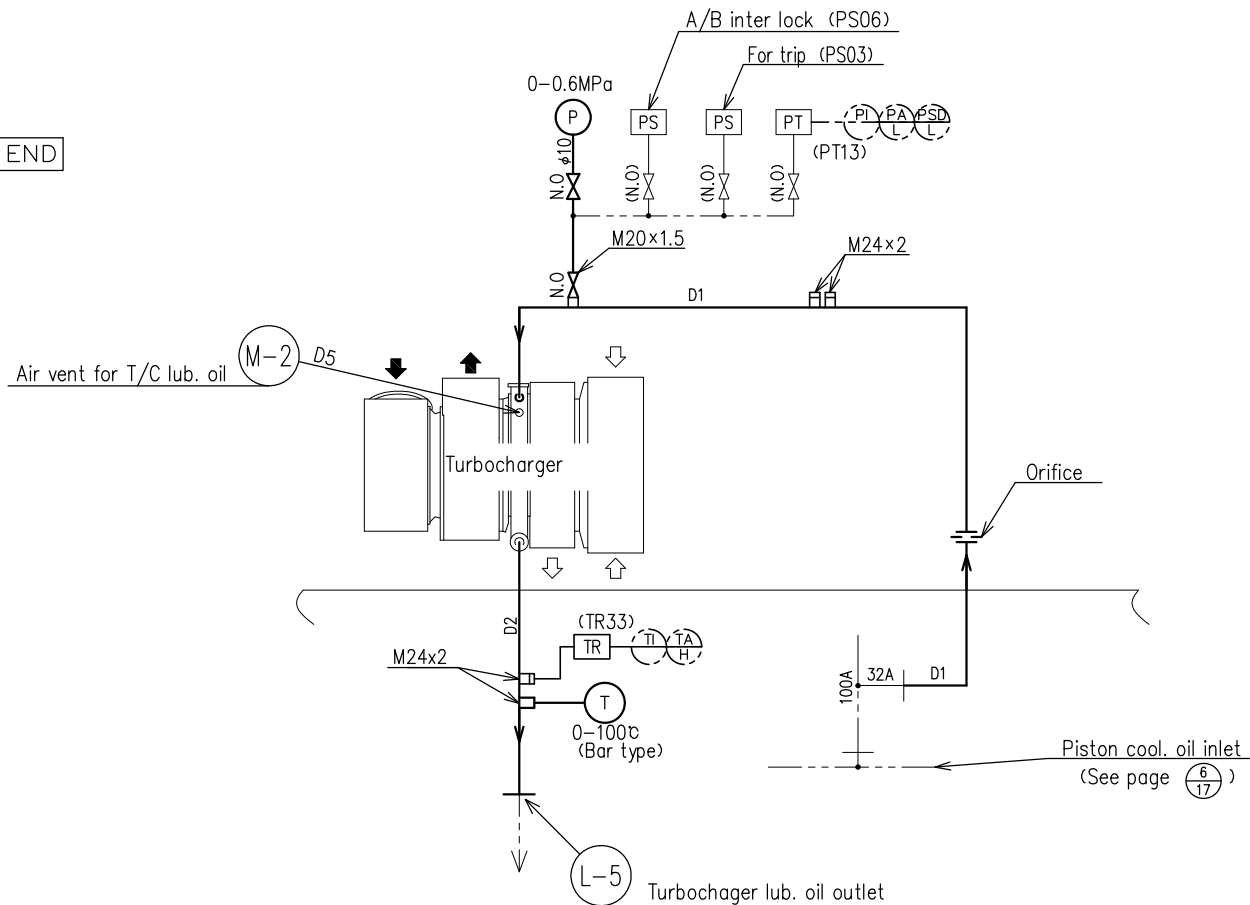

View from exhaust side

Turbocharger type	Pipe sizes		
	D1	D2	D5
MET53MB/-EGBx1	32A	65A	65A
MET48MB/-EGBx1	32A	65A	65A

6UEC50LSJ

Piping diagram of
Turbocharger lubricating oil

過給機潤滑油管線図

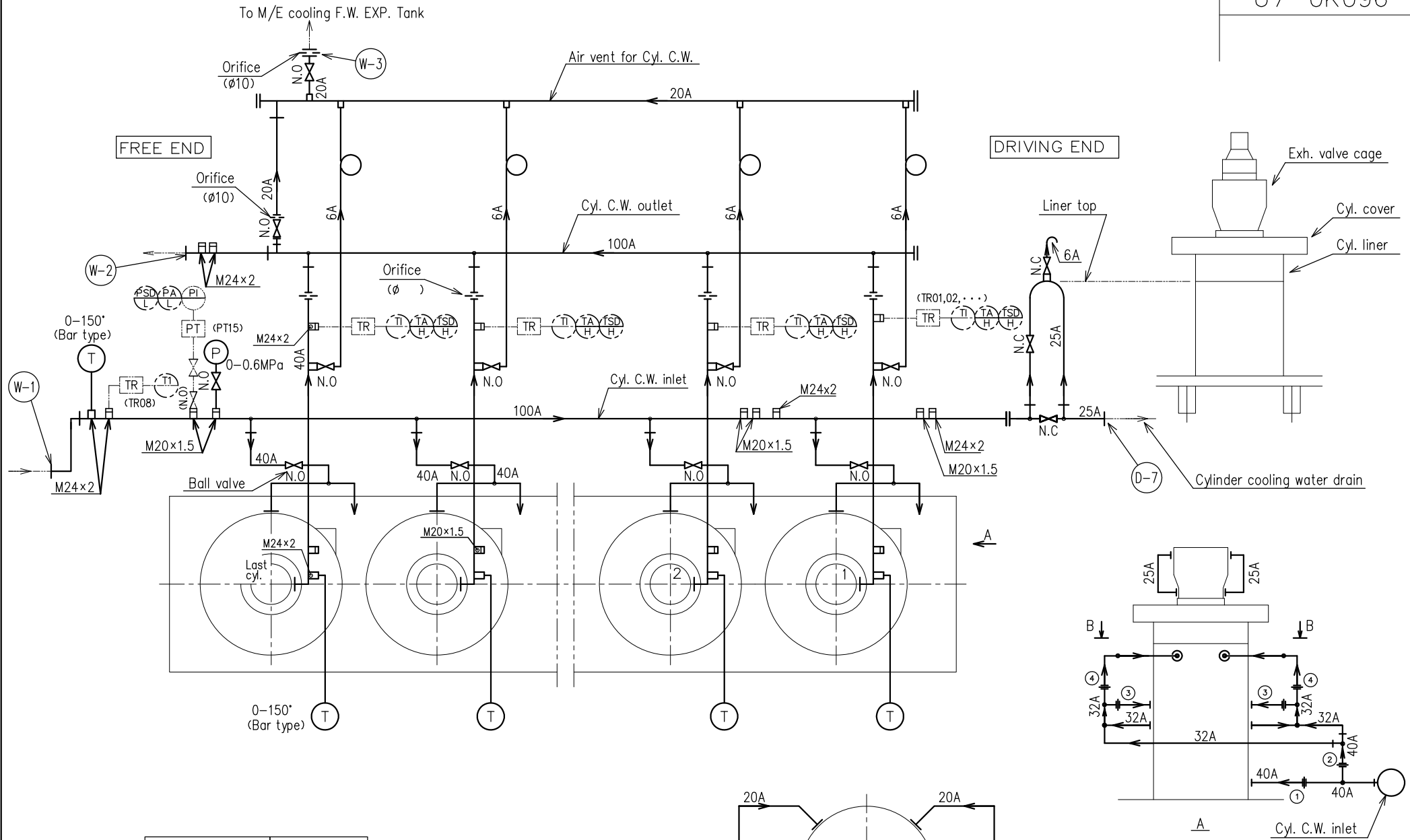

Orifice	φ (mm)
①	
②	
③	
④	

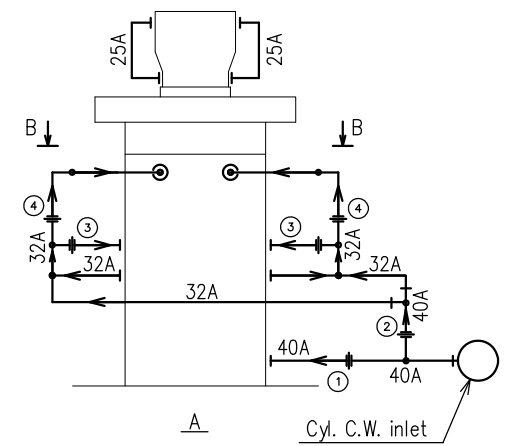
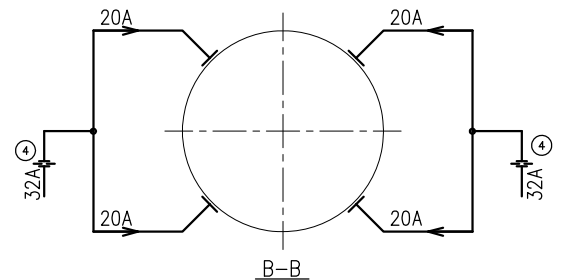

6UEC50LSJ
 Piping diagram of cylinder cooling water (Uniflow cooling)
 シリンダ冷却水管線図 (ユニフロー冷却) 11-1/17

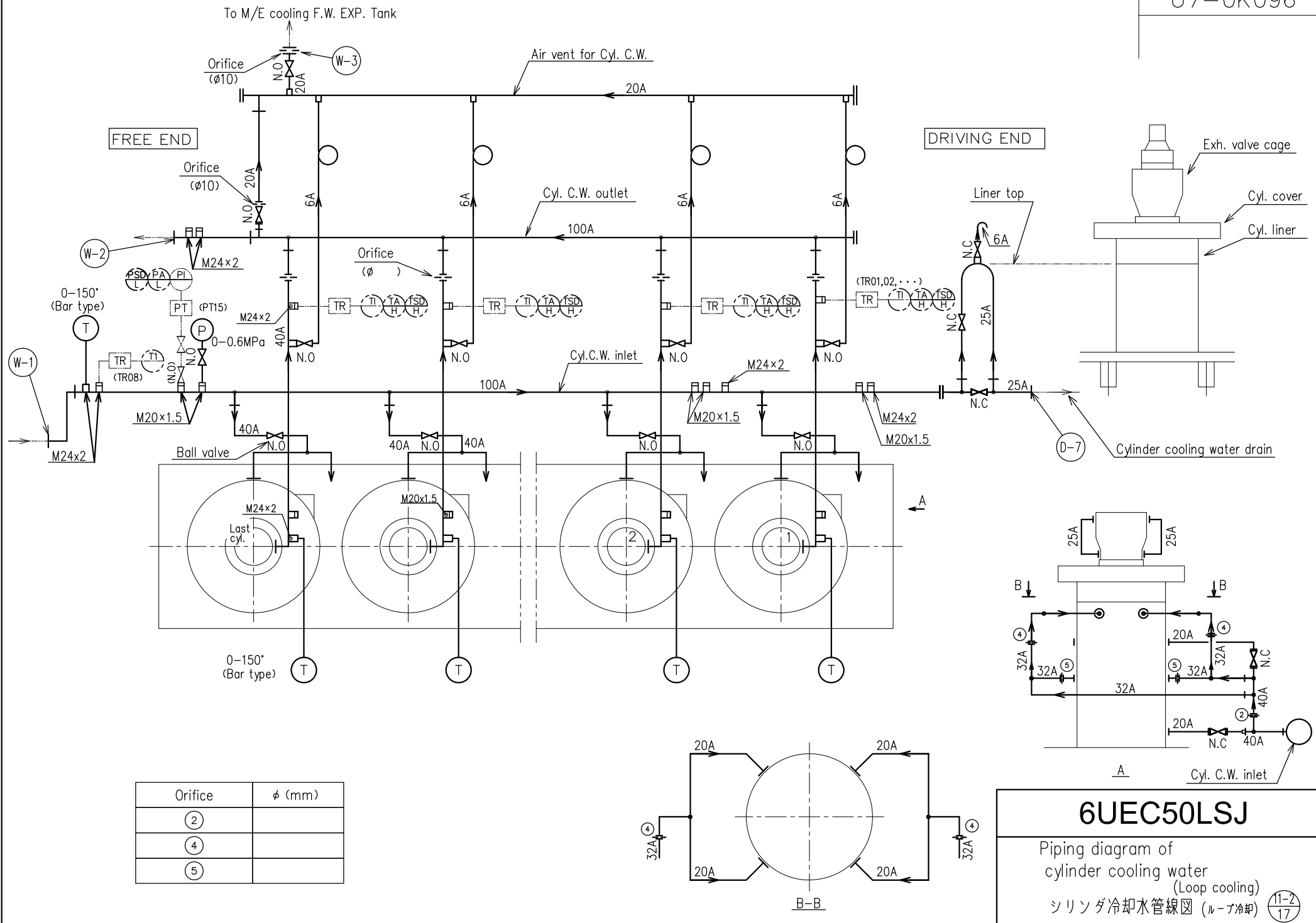

Orifice	φ (mm)
②	
④	
⑤	

6UEC50LSJ

Piping diagram of cylinder cooling water (Loop cooling)

シリンダ冷却水管線図 (ループ冷却) ⑪-② 17

FREE END

DRIVING END

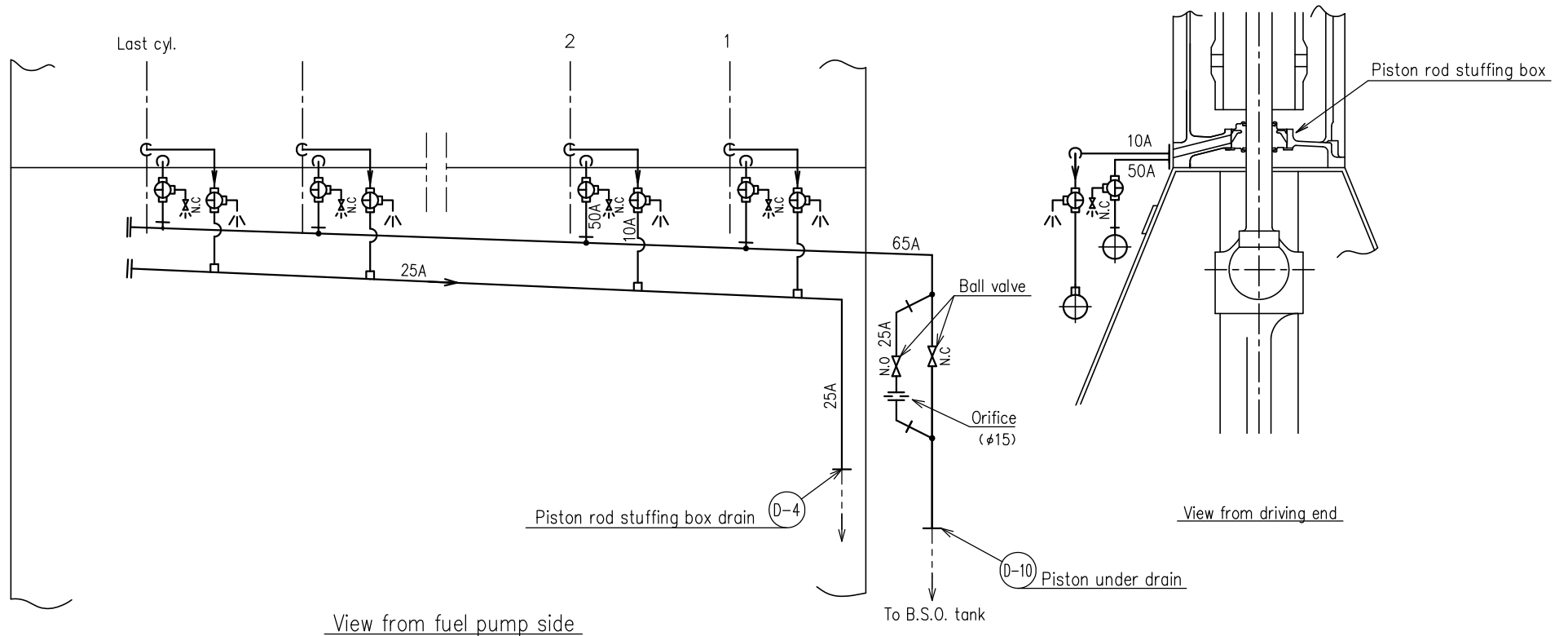

6UEC50LSJ

Piping diagram of
piston rod stuffing box drain

ピストン棒パッキン箱ドレン管線図

DRIVING END

FREE END

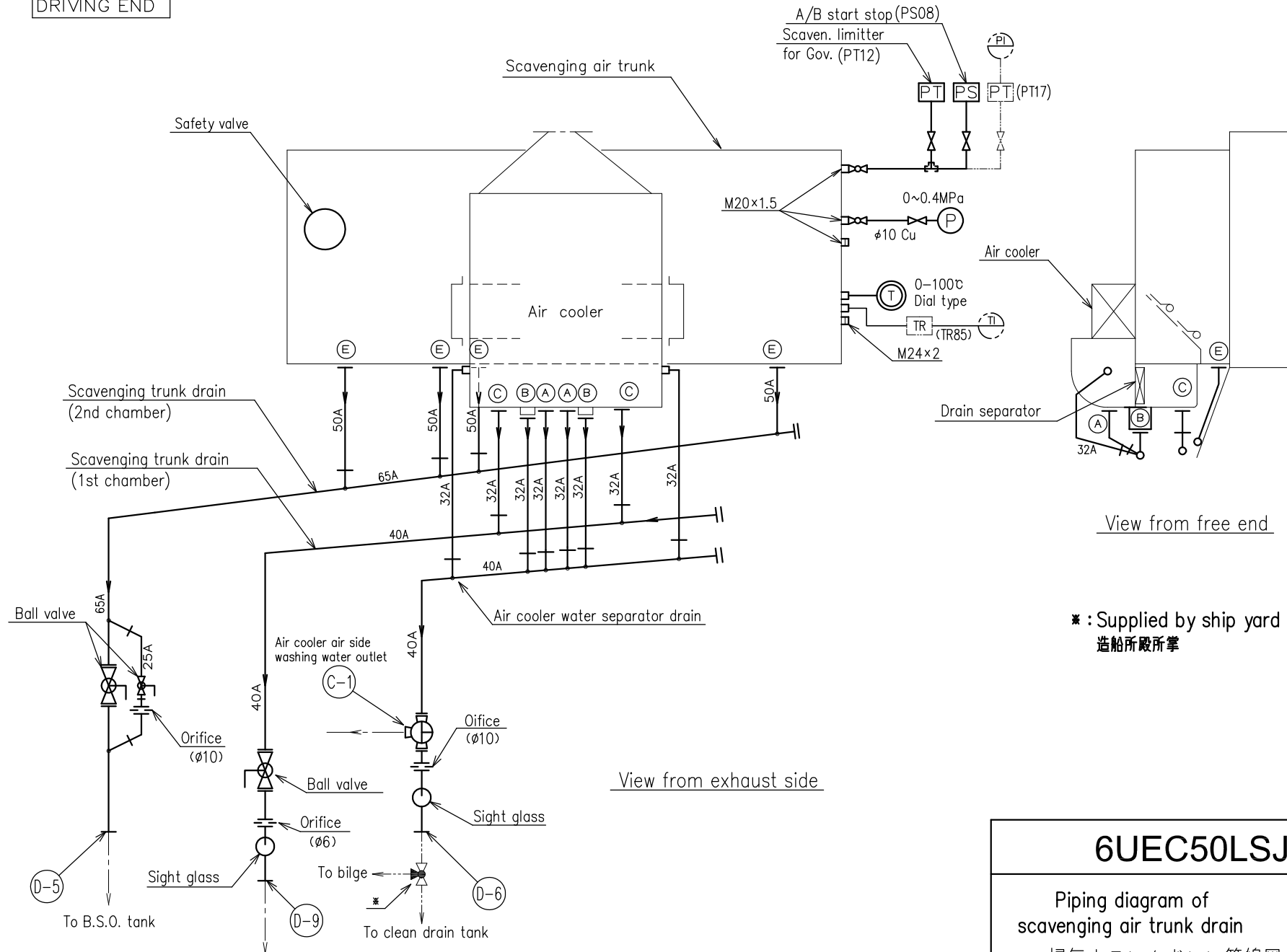

View from free end

View from exhaust side

* : Supplied by ship yard
造船所殿所掌

6UEC50LSJ

Piping diagram of
scavenging air trunk drain

掃気トランクドレン管線図

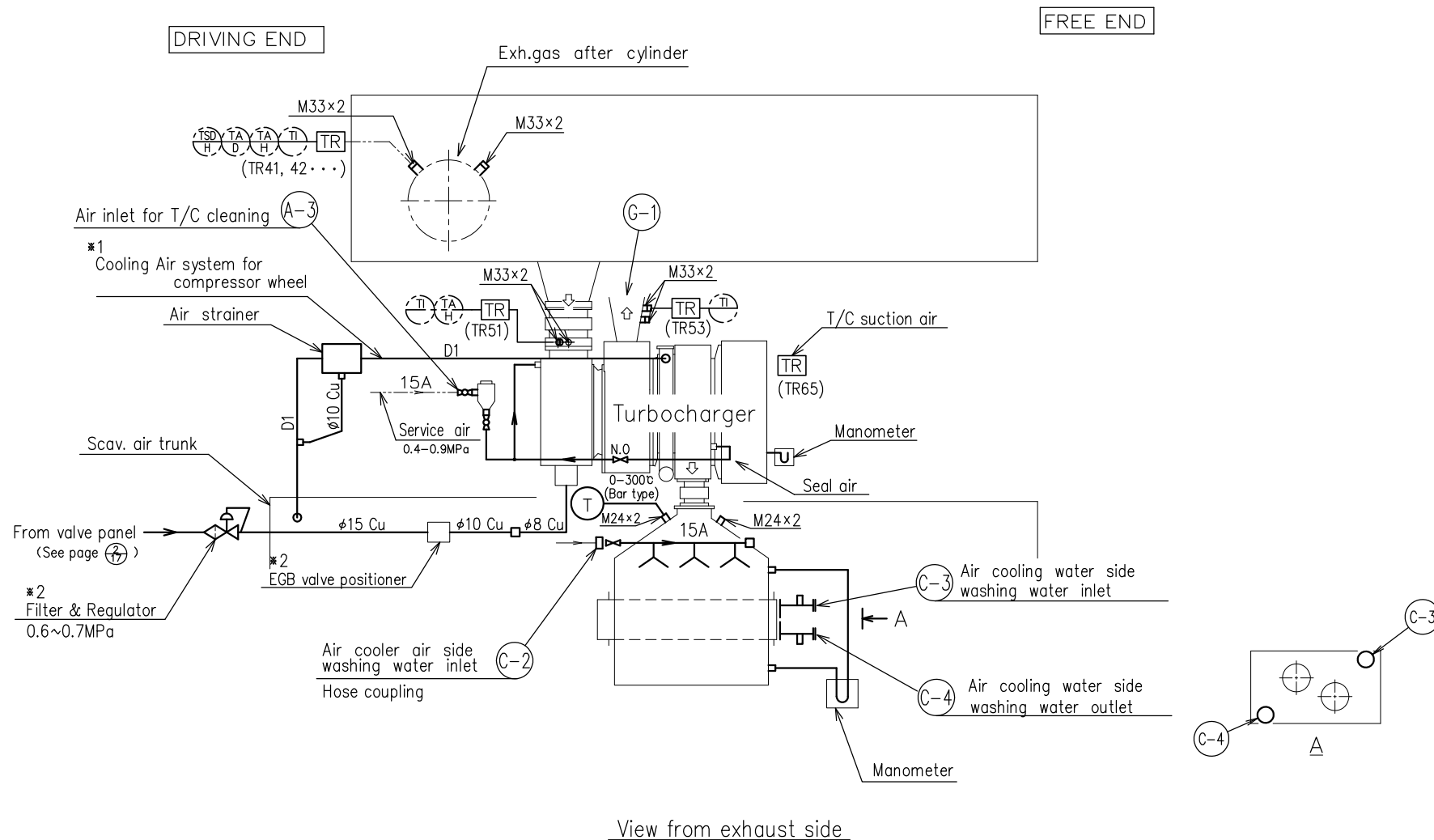

View from exhaust side

Turbocharger type	Pipe size
	D1
MET53MB/-EGBx1	40A
MET48MB/-EGBx1	40A

*1. クーリングエアシステムは、機関の仕様により必要となる場合があります。
お問い合わせください。

Depending on the engine specification, cooling air system may be required.

*2. MET-EGB 過給機のみ。

Only for MET-EGB type turbocharger.

6UEC50LSJ

Piping diagram of turbocharger and air cooler washing water and exhaust gas system

過給機空気冷却器洗浄水管及び排気ガス線図

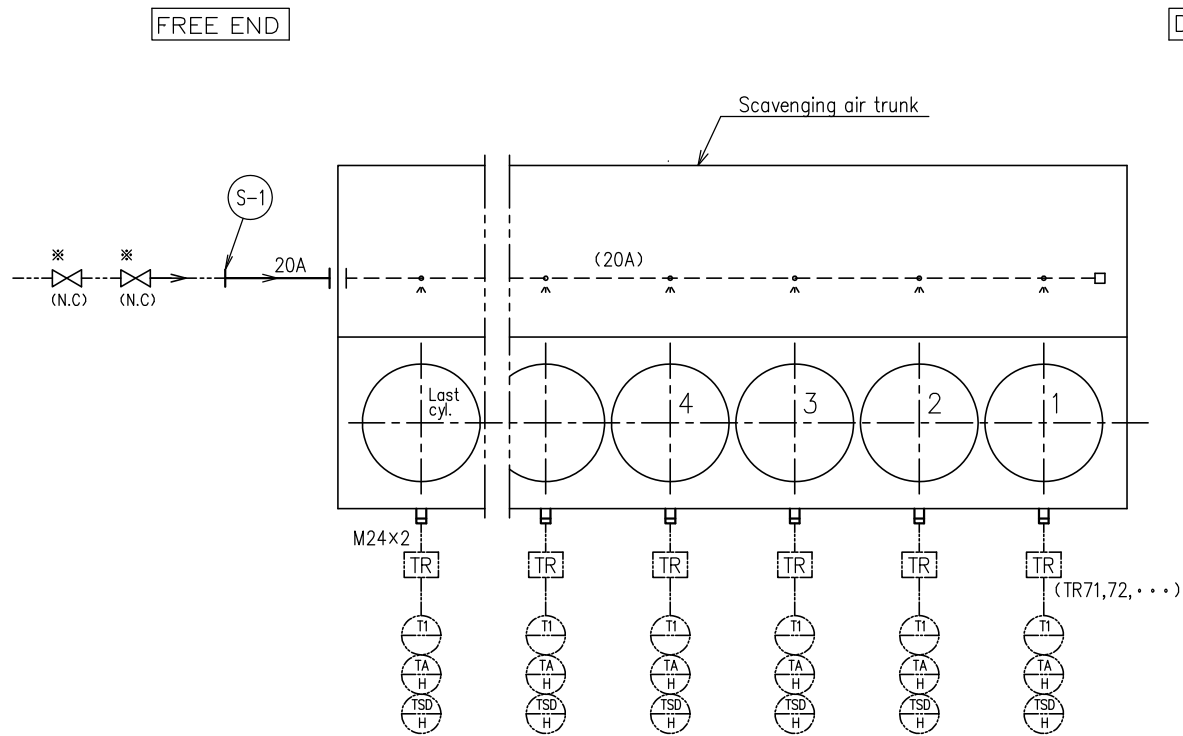

※ Supplied by shipyard.
造船所殿所掌

6UEC50LSJ

Piping diagram of
fire extinguishing

掃気室火災消火装置管線図

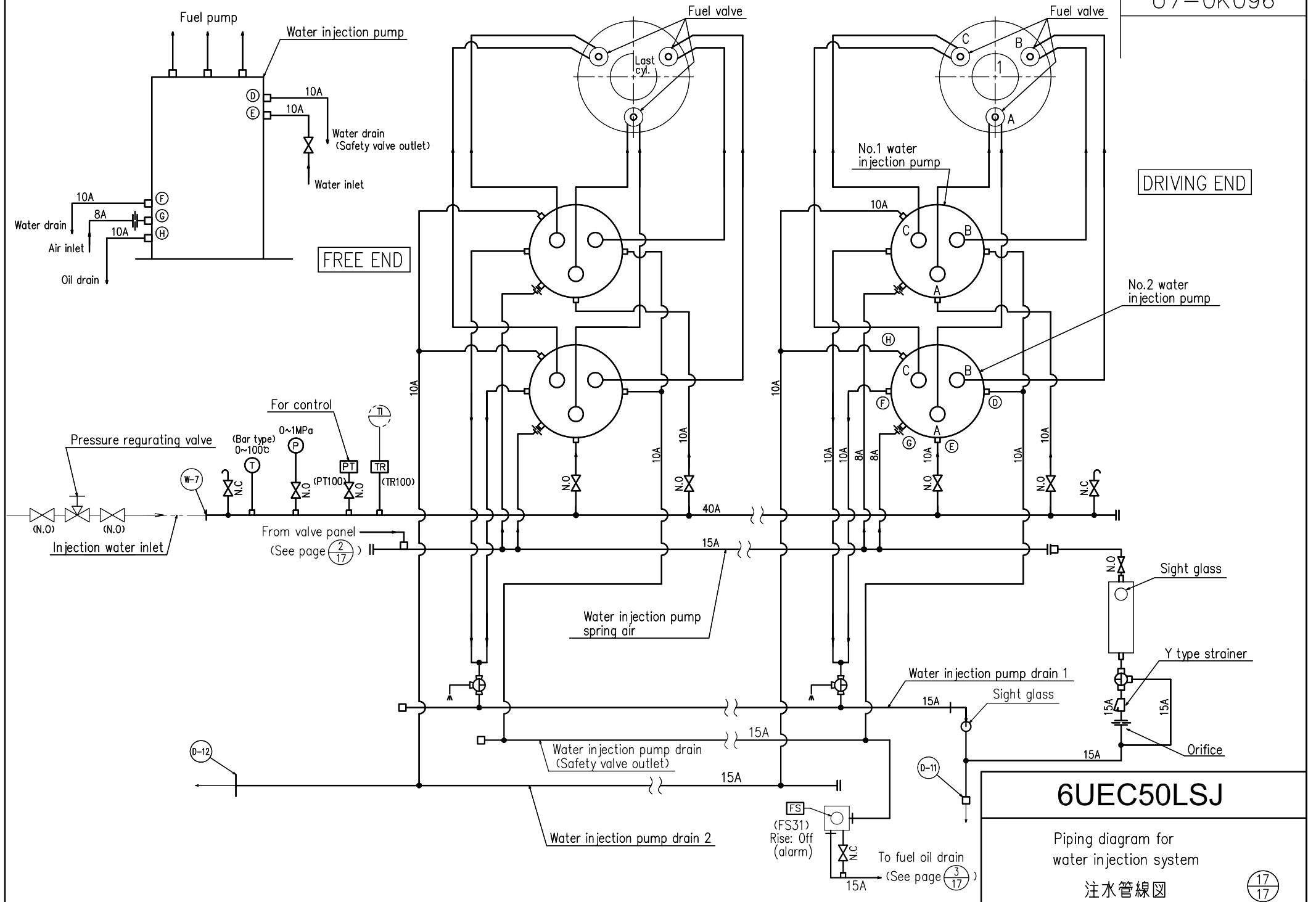

DRIVING END

FREE END

6UEC50LSJ

Piping diagram for water injection system

注水管線図

